

THE  
**BARRETO**  
MODEL 912  
HYDRAULIC TRENCHER

CONGRATULATIONS!

You are now the proud owner of the BARRETO Model 912 trencher. Please take a moment of your time to look over the following information. Familiarize yourself with the trencher, its characteristics, and method of operation. Pay particular attention to the safety and operating instructions.

If you have any questions or need any replacement parts in the future, please contact us at your convenience. Our toll-free phone number, fax and email are listed below.

THANK YOU for your patronage and confidence in BARRETO equipment.

Barreto Manufacturing, Inc.  
Innovative Equipment Engineered to Last  
66498 Hwy 203, La Grande, OR 97850  
(800) 525-7348 (541) 963-7348  
FAX (541) 963-6755  
E-Mail: [info@barretomfg.com](mailto:info@barretomfg.com)  
Web Site: <http://www.barretomfg.com>

## 912 TRENCHER ASSEMBLY INSTRUCTIONS

1. Remove trencher from shipping crate.
2. Install boom onto boom pivot/mount. Push boom on as far as it will go. Be sure adjuster screw is backed out.

### SERVICE INFORMATION

1. Your trencher should arrive with 10 gallons of hydraulic fluid in the tank. Check reservoir level using sight glass on the right side of the tank. If required, add to reservoir with tractor transmission hydraulic oil. (Shell DONAX TD FLUID or comparable.)
2. Recheck oil level after trencher has been run and oil has circulated through wheel and chain motors. Routinely check level thereafter.
3. Change hydraulic oil filter after the first 50 hours of use. Change it every 200 hours thereafter.
4. Add 1 quart of hydraulic oil to reservoir with each filter change.
5. Check all hydraulic fittings for leaks and tighten if necessary.
6. The grease zerk on chain shaft housing should be greased after every 4 to 8 hours of use. The grease zerk in the front wheel should be greased after every 8 hours of use.
7. Grease zerks on cylinder rod end and boom pivot should be greased daily.
8. Grease zerks on each side of the boom cylinder and on front wheel hub should be greased once a week
9. Grease zerks on the wheel hubs and hub lock screws should be greased and freewheeled once a week or so, depending upon free wheel use.

(See page 10 for illustrations of lubrication points.)

**IMPORTANT:** The engine on the Barreto trencher is normally serviced prior to shipping. However, shipping regulations may prohibit shipping with fuel or oil in the machine. Check levels and add oil and fuel as required before starting engine. Service engine according to the engine manual before starting.

**WARNING:** Running the trencher without hydraulic oil will cause serious damage to the hydraulic pump. INSURE THAT THE RESERVOIR OIL LEVEL IS TO THE SIGHT GLASS BEFORE STARTING THE MACHINE.

## CHAIN INSTALLATION

1. Slide chain under sprocket, with teeth in the correct cutting direction. Properly installed, the cutting edges of the chain will face forward on the top of the boom and rearward on the bottom of the boom (see diagram below).
2. Push digging boom control lever forward to lower boom onto the chain.
3. Wrap chain around boom and sprocket. Install chain master link or link pin.
4. Use boom adjuster screw to tighten chain. Chain should have enough slack to allow approximately 1" to 2" of space between middle of boom and chain when boom and chain are straight out in a horizontal position.
5. Tighten adjuster screw locknut.

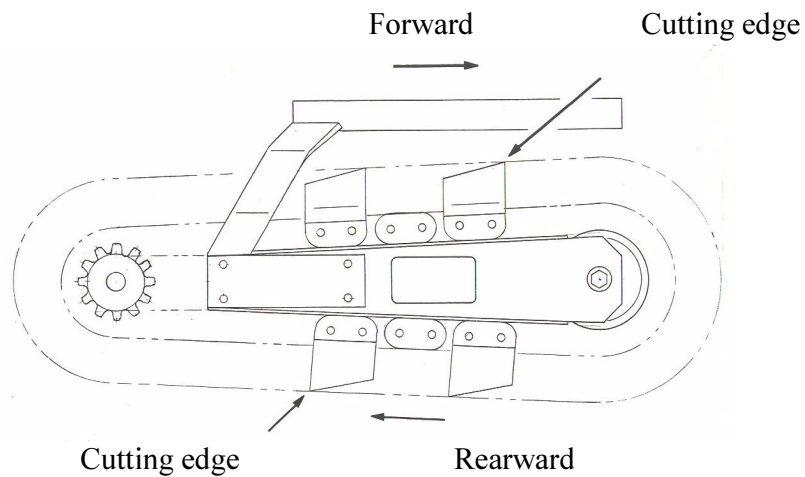

# 912 TRENCHER OPERATING INSTRUCTIONS

## READ SAFETY INSTRUCTIONS BEFORE OPERATING!

Be sure that the engine oil, fuel and hydraulic oil are at proper levels before starting the engine.

## STUDY AND UNDERSTAND CONTROLS BEFORE BEGINNING OPERATION.

1. **FREE WHEELING HUBS:** To engage either hub, turn the lock pin handle in (clockwise). This allows the spring-loaded pin to engage. Repeat for the other wheel. Push the trencher a bit if necessary until each pin finds a hole to drop into. The hubs are now locked. Disengaging one hub makes it much easier to turn the trencher when transporting under power.
2. **ENGINE IGNITION:** Must be in ON position to start the engine. Move to OFF position to stop the engine.
3. **ENGINE THROTTLE:** Controls engine speed. Operate at full throttle.
4. **CLUTCH LEVER:** Squeeze to activate the Wheel Drive and Dig Chain. All motion stops when the lever is released. It is located on the left handlebar.
5. **WHEEL DRIVE CONTROL:** Controls travel direction and speed. Very slow speed is required for trenching in most conditions. Begin trenching with the wheel control in neutral. Then adjust the reverse speed when trenching. NOTE: Be sure operator understands that the machine moves BACK when trenching, not forward.
6. **DIG CHAIN ON/OFF CONTROL:** To trench, hold lever in ON position while clutch lever is activated. The ON/OFF lever will stay in position as long as the clutch lever is held. This automatically will activate the CHAIN FORWARD/REVERSE LEVER to FORWARD position.
7. **CHAIN FORWARD/REVERSE LEVER;** Use this lever to reverse chain to help clear debris from the chain. The clutch lever must be released to put the chain lever in reverse.
8. **DIGGING BOOM CONTROL:** Pull to raise the digging boom and push to lower the boom. During normal operation you will hear a relief valve working.

## GETTING STARTED:

1. Start and warm up engine.
2. Put Wheel Drive control in neutral.
3. One wheel hub may be disengaged (free wheeling) for easier steering before driving machine to work location.
4. Squeeze the clutch lever and change the Wheel Direction Control to desired speed and direction.
5. Adjust the wheel speed and navigate the trencher to the starting position. The trencher is designed to dig toward the operator (with the Wheel Drive Control in reverse). With this in mind, position the machine to start the trench.

## TRENCHING PROCEDURE:

1. Put Wheel Drive Direction Control in neutral
2. Be sure both hubs are engaged.
3. Have engine at full throttle (forward).
4. Hold Dig Chain On/Off Control in On position.
5. Squeeze the clutch lever.
6. Slowly lower the digging boom until the desired trench depth is achieved.
7. Put Wheel Drive Control in reverse. Start at slow speed.
8. Adjust the wheel speed until a workable speed is reached. Use a very slow speed for trenching and adjust for soil conditions as necessary. If objects such as rocks or roots jam in the chain, release the clutch lever, then reverse the chain to dislodge the debris. If necessary move the trencher forward a few inches and trench the area again.

# BARRETO HYDRAULIC TRENCHER

## SAFETY INSTRUCTIONS

- **READ SAFETY AND OPERATING INSTRUCTIONS BEFORE OPERATING!**
- **USE COMMON SENSE AND PLENTY OF IT!**
- Do not leave trencher unattended with the engine running.
- Always leave trencher parked on a level surface, and lock the hubs.
- The **SAFETY CLUTCH LEVER** on the left handle bar is for operator protection. **DO NOT TAPE DOWN LEVER** or otherwise by-pass this safety feature.
- Objects may become airborne while operating trencher. Wear safety goggles and a hard hat while operating or observing!
- Digging chain, auger and other moving parts can cut off arms, legs, or fingers. **STAY CLEAR!**
- Buried cables or gas lines can cause serious injury or death if struck with dig chain. Contact local agencies for location before digging.
- Fuel exhaust and fuel fumes can cause illness or death. Operate outdoors and avoid breathing exhaust and fumes.
- Fuel fumes can catch fire or explode. Do not smoke or operate near flames or sparks.
- Hydraulic oil is under extreme pressure and can get under skin and burn or poison. Check for leaks with cardboard.
- Muffler and engine get hot enough to cause serious burns. Do not touch until cool.

## BARRETO MANUFACTURING, INC. EQUIPMENT WARRANTY

Barreto Manufacturing, Inc. warrants all BARRETO equipment to be free of defects in material and workmanship for a period of one (1) year, dating from delivery to the original user.

This Warranty is in lieu of all other warranties, whether written or implied, and is limited to:

1. Replacement of parts returned to the dealer and/or factory and determined defective upon inspection. (Replacement for parts to dealers shall be at dealer cost plus shipping charges.)
2. Time for pick-up and/or delivery, transportation or service calls by dealers is excluded. Manufacturer reserves the right to determine reasonable time required for repair.

Warranty does not apply to damage caused by abuse or neglect. Time and materials required for normal maintenance and service are also excluded from warranty coverage.

Engines, engine accessories and tires are warranted by the original manufacturers and are not covered by the Barreto Equipment Warranty.

## WHEEL DRIVE VALVE CABLE ADJUSTMENT

The clutch cable and lever must have some free play. The cable will stretch and occasionally needs adjustment.

1. Rotate the actuator arm clockwise, by hand, to take up any free play. Measure the distance from the pin of the actuator arm to the end of the cable housing.
2. Pull the clutch lever all the way up until it touches the handle bar grip. With the lever pulled up, again measure the distance from the pin of the lever to the cable housing. Calculate the difference.
3. Adjust the cable for  $7/16''$  to  $1/2''$  movement of the actuator arm at the pin. Do not include any lever free play in the measurements.

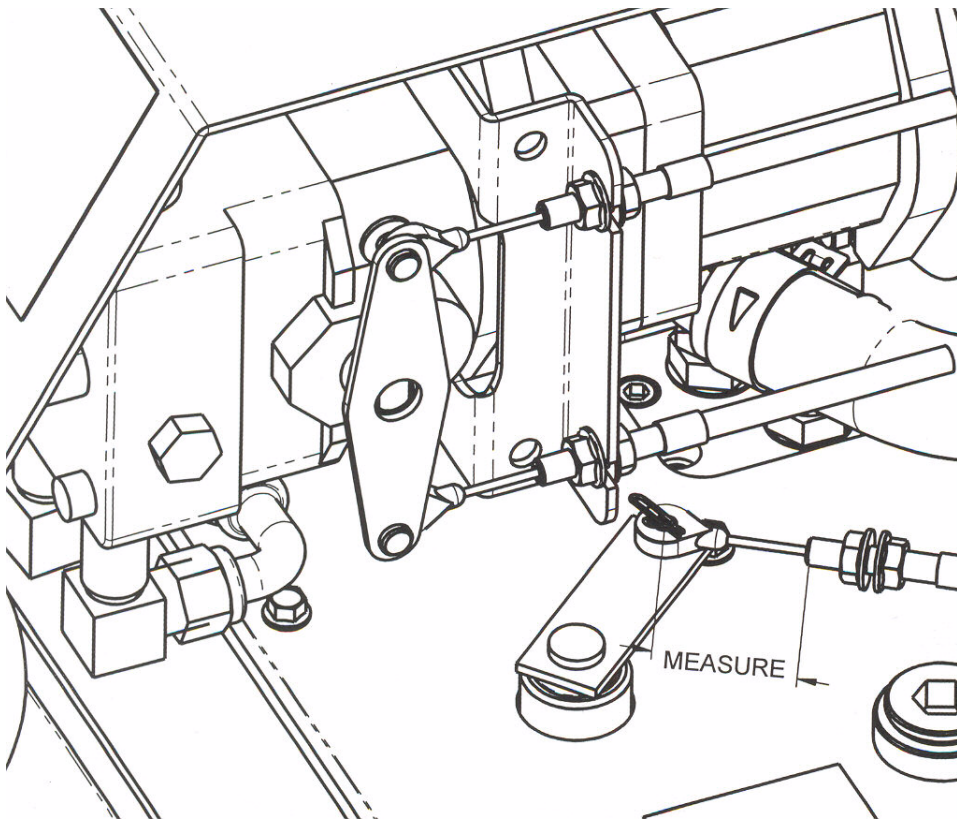

## WHEEL DRIVE NEUTRAL ADJUSTMENT

The speed control cables may need to be adjusted after some use. If the machine creeps while the speed control is in neutral, the speed cables will need adjustment. Adjust the cables to bring the pump cable arm to the neutral position (vertical) when the speed control also is in neutral. Adjust the cables to eliminate slack, but do not over tighten them so they are extremely tight against each other.

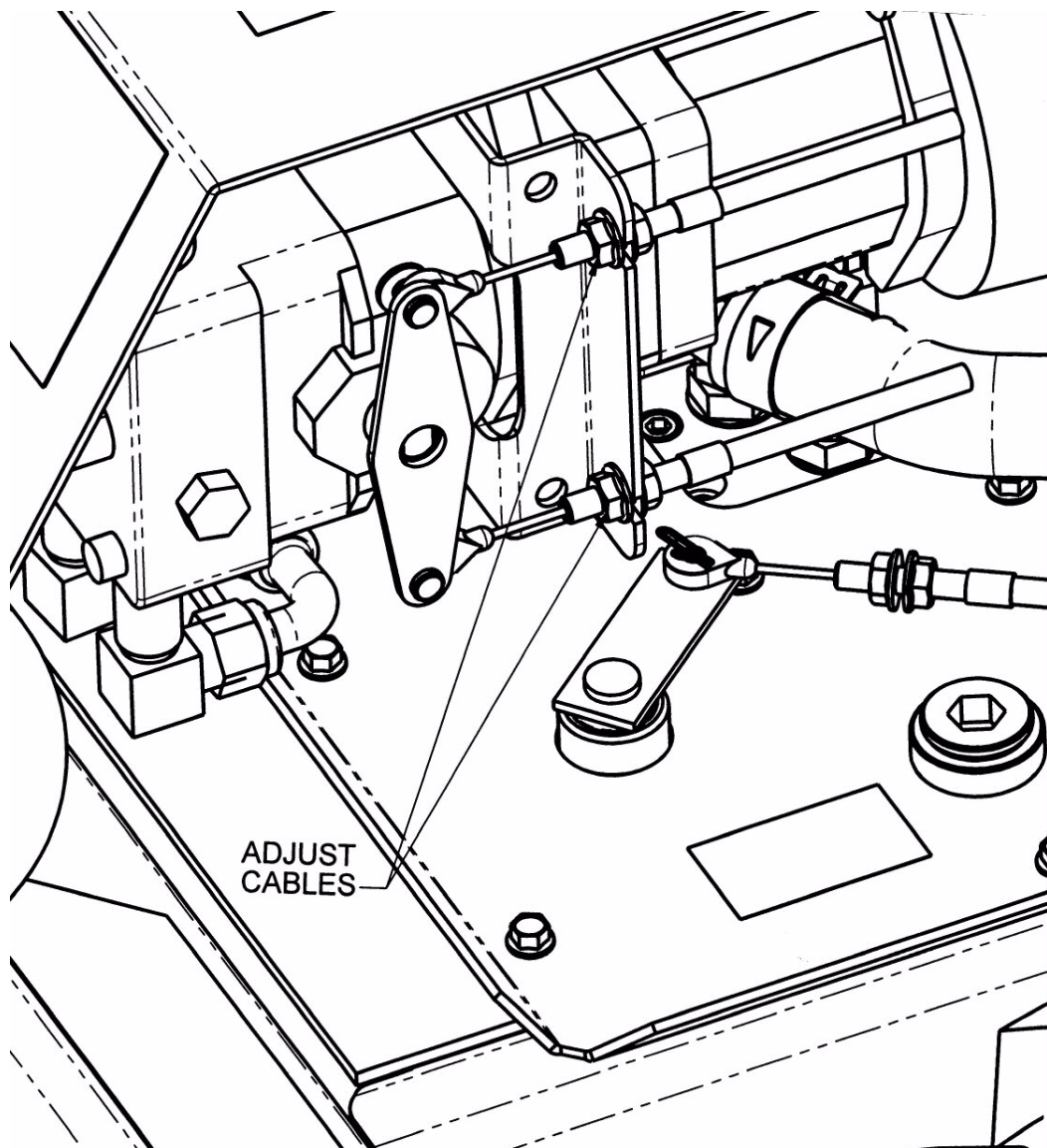

## CHAIN VALVE ADJUSTMENT

The chain valve control should be adjusted to completely activate the chain valve when the dig chain control is in 'ON' position. To check this adjustment, put the chain on/off control in ON position (with engine stopped). Pull the clutch lever on left handlebar up until it touches the handgrip. While holding clutch lever up, push on the chain forward/neutral/reverse lever. It should be at the end of its stroke, thus not move down any more. If the chain F/N/R lever can be pushed down more, the valve spool lever should be adjusted. To adjust, remove back cover from the control panel. Loosen the 2 bolts on valve lever and rotate the lever plate down about 1/16". Re-tighten the bolts and check the lever stroke. Adjust so the valve lever comes to the end of its stroke just as the clutch lever touches the handgrip when chain valve control is in ON position.

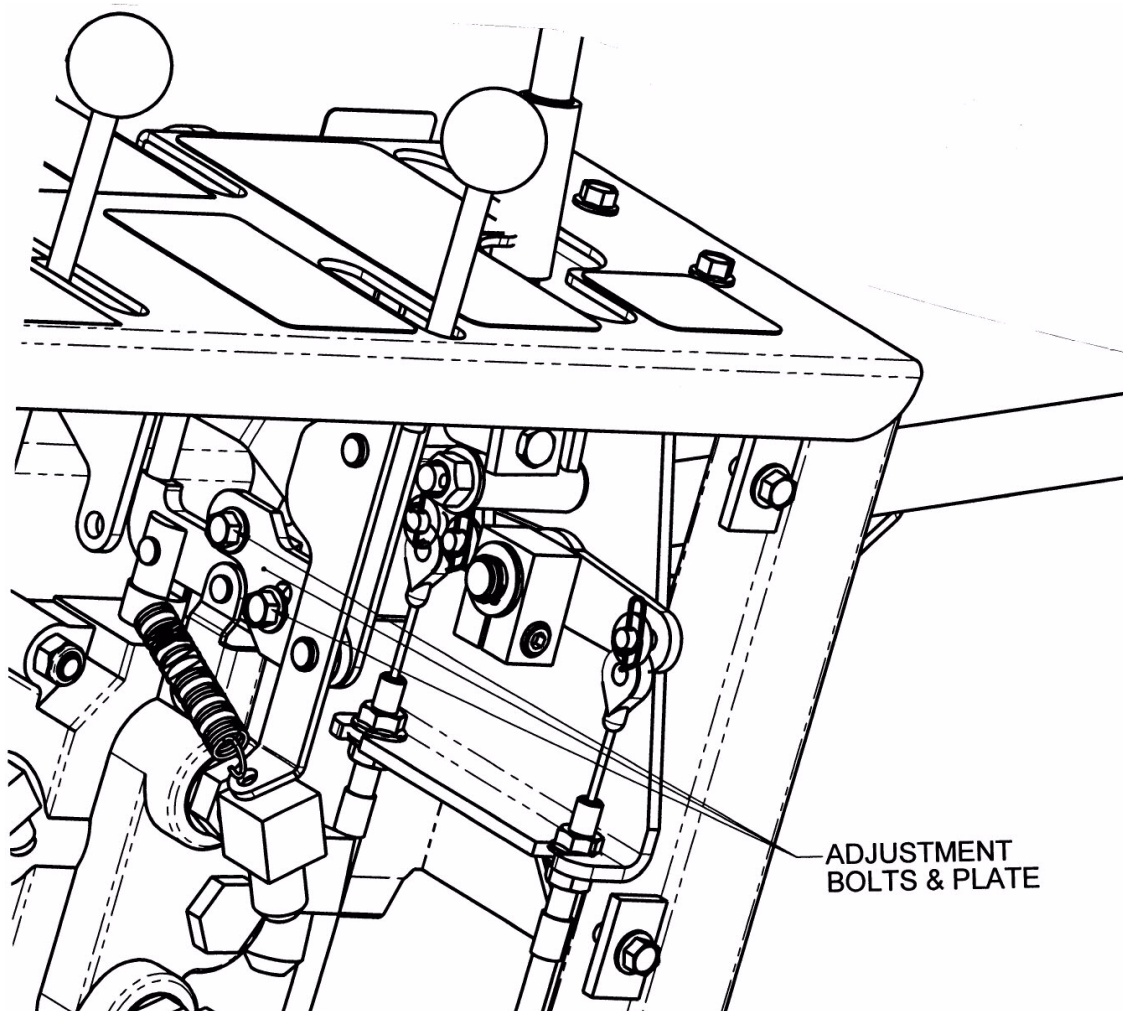

## Daily Lubrication Requirements

Be sure to grease all lubrication points as outlined on page 2 of this manual.

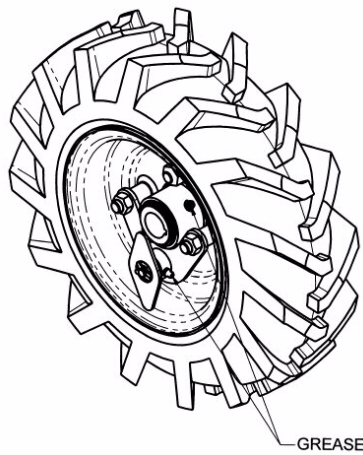
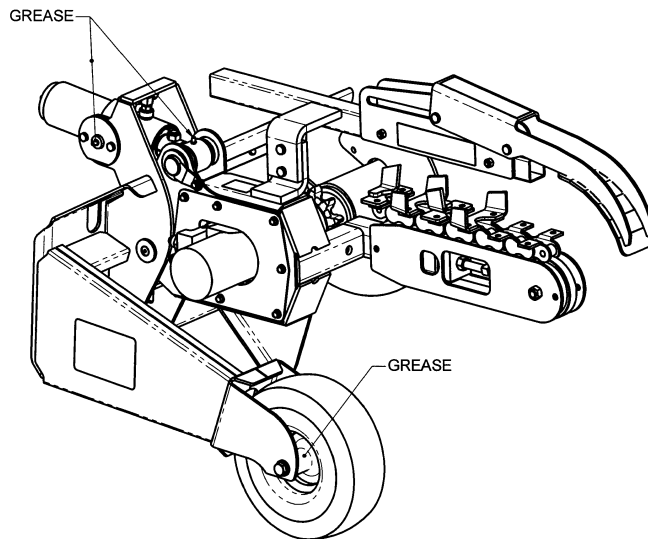
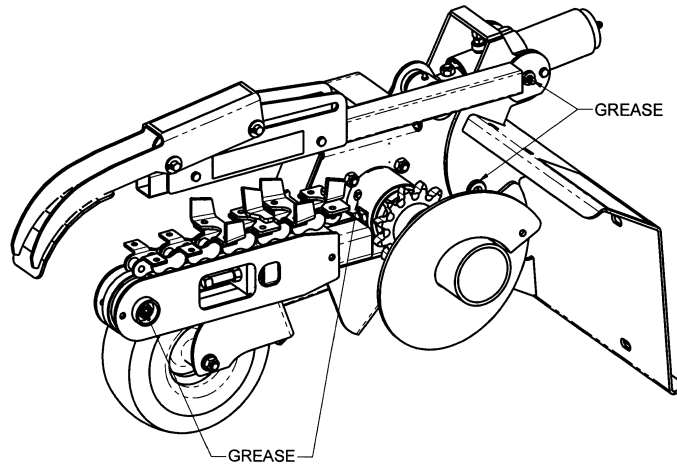

## 912 TRENCHER TROUBLE SHOOTING GUIDE

**CAUTION!!** Always use extreme care when trouble shooting or making adjustments on trencher. Stay clear of chain and auger when engine is running. Stop engine before disassembling any component.

### **A. Entire hydraulic system does not operate and the engine is not under load.**

- |   |  |
|---|--|
| 1. Broken or improperly adjusted clutch (actuator) cable. | See clutch cable and actuator arm adjustment. Adjust or replace cable.       |
| 2. Low hydraulic oil in tank                              | Add oil until it shows in sight gauge.                                       |
| 3. Hydraulic pump-to-engine coupler has slipped.          | Check for wear and replace both coupler halves and rubber spider, as needed. |

### **B. Engine lugs down or dies and wheels and chain do not turn.**

- |  |  |
|--|--|
| 1. Rocks or other obstructions stopping chain.             | Reverse chain momentarily to free it from obstruction. Raise boom and stop chain. See if obstruction can be removed from trench. |
| 2. Trenching depth or speed too great for soil conditions. | Decrease ground speed or trenching depth.  |
| 3. Engine improperly tuned or maintained.                  | See engine manual and correct as needed.   |
| 4. Low oil alert causes engine to shut down.               | This may occur when trenching on hills. Level trencher, check oil and allow oil alert to reset.                                  |
| 5. Engine losing power due to wear.                        | See engine manual.   |

## 912 TRENCHER TROUBLE SHOOTING GUIDE (Continued)

**CAUTION!!** Always use extreme care when trouble shooting or making adjustments on trencher. Stay clear of chain and auger when engine is running. Stop engine before disassembling any component.

### **C. Chain fails to rotate, but wheel drive works.**

- |  |  |
|--|--|
| 1. Chain motor worn                          | Rebuild motor or replace with exchange motor.                      |
| 2. Chain Control Relief Valve Malfunctioning | Adjust Relief Valve to 2200 psi or replace relief spring if needed |

### **D. Wheels fail to turn, but chain rotates.**

- |  |                                       |
|--|---------------------------------------|
| 1. Hubs unlocked.                        | Lock the hubs                         |
| 2. Wheel axle key sheared                | Replace key and other parts as needed |
| 3. Wheel Drive Valve not fully activated | Adjust valve cable as shown on page 7 |
| 4. Speed Cable broken or disconnected    | Replace or re-connect cable           |
| 5. Pump Cable Lever loose on shaft       | Tighten setscrew on Pump Lever        |

### **E. Oil leaks in hydraulic system.**

- |                                    |   |
|------------------------------------|---|
| 1. Fittings are loose              | Tighten fittings on hoses and adapters  |
| 2. Worn or broken hoses            | Replace damaged hoses   |
| 3. Oil around chain motor or shaft | Inspect motor for leaking shaft seal.<br>Rebuild motor or replace with exchange motor |

## 912 TRENCHER TROUBLE SHOOTING GUIDE (Continued)

**CAUTION!!** Always use extreme care when trouble shooting or making adjustments on trencher. Stay clear of chain and auger when engine is running. Stop engine before disassembling any component.

### **F. Foaming hydraulic oil coming from breather hose.**

- |                         |  |
|-------------------------|--|
| 1. Improper oil used.   | Verify that hydraulic oil used had antifoaming additives. Recommended oil is tractor hydraulic. (Shell Donax TD or comparable) |
| 2. Air leaking into oil | Inspect and tighten fittings and clamps on pump and hoses  |

### **G. Boom does not lift, or does not lower into ground.**

- |  |  |
|--|--|
| 1. Boom lift relief valve malfunctioning | Adjust relief to 500 psi. This may require a replacement spring in valve |
|--|--|